

BRAZOS MUTUAL DOMESTIC WATER CONSUMERS ASSOCIATION, INC.

2022 Annual Newsletter

P. O. Box 92945
Albuquerque, New Mexico 87199
Official Website www.bmdwca.com

Annual Meeting of the Brazos Mutual Domestic Water Consumer's Association, Inc. (BMDWCA) will be held on Saturday, May 28th, 2022 at the Brazos Fire Station. Meeting will begin at 10:00am.

It is with great sadness to report that John Hoffman passed away on January 17, 2022. He was a giant in the Brazos with system knowledge and a spirit of helping others. As your board secretary writing this, John was the only board member who took the time to explain the entire system and showed me why we very often had no water on Falls Creek Rd. We were always told we had a leak, and later discovered that was not the case. With this new system knowledge, I was able to put in a storage tank and pressure pump and ever since my water issues have been solved. John will be greatly missed. This community will feel his loss in the days going forward. Thank you, John, for all you did for this community!

As many of you know, 2020-2021 presented some huge challenges. Getting through the COVID lockdowns and trying to maintain some form of normalcy has been difficult. Our thoughts and prayers go out to the many who have lost loved ones, suffered from the virus themselves, and altered their way of life beyond our wildest expectations. The board did the best we could to plan ahead, trying to anticipate the governor's orders, which is why we did not have an annual meeting in 2020 and 2021. The current board has been meeting regularly in all of 2020 and 2021. So, based on these decisions, we were not able to conduct a formal election in 2020, as well as in 2021. All of the current board members agreed to stay on and conduct board business regardless of their terms, doing what we could do to keep the BMDWCA in full operation. Letters were sent out notifying the community of our decision and we did not have any issues raised from the community. There are six (6) board members whose term has expired, and three (3) that expire in 2022. We have not been able to have an Election/Annual Meeting in 2 years, and have been polling the community during that time for potential board members. Your current board has served multiple/triple terms and has been looking for new faces to fill these positions. We have received 5 petition ballots and 2 additional names. The Annual Meeting is set for Saturday, May 28th, 2022 at the Brazos Fire Station at 10:00am. Since the current board members have served this community with multiple/triple, and extended terms, it's time for some new board members! We feel it is imperative that all members, especially full timers, take a vested interest by serving on the board. If your desire is to have a working system, you had better get involved. Please volunteer for a board position as soon as possible. The Brazos community needs your help! We trust you will find this letter informative regarding the board's actions and progress in the community with the intent to keeping our water system flowing.

I want to take this opportunity to say thank you to the following individuals who served these past years and continue to serve on the board. Jim Walker (Vice-President), Jay Mason (Treasurer), David Oelschlegel (Secretary), Marco Lucero (Director), Richard Dramer (Director), Curtis Goodfellow (Director), Clay Kilmer who was replaced by Eddie Kilmer (Director), and Arch Wells (Director). They are hardworking, selfless, and very dedicated to making this water system the best it can be, especially with today's circumstances.

Our snowfall and rain, once again was less than desirable in 2020-2021, and 2022 is looking like another very dry year. We are being told by forecasters that we are expected to be in a La Niña pattern which is

warmer and dryer than normal. Our wells struggle to keep up according to our operator. We had a leak this past year that never surfaced, despite months of searching. Our operator estimates we are losing a significant amount of the water we are collecting. After hiring American Leak Detection Service for a full three (3) days, we were able to find many trouble spots, and got them corrected. Sticky valves, hydrants, and stop and waste valve issues not being turned on/off correctly, may have been a source of some of our troubles. This issue started in the late summer of 2021 and was a great inconvenience for everyone. Rural Water sent out two (2) certified operators numerous times. As of the close of winter, we have not found this leak. We feel Well House 3 is suspect since it contains lots of galvanized original plumbing. We have requested some capital outlay and potential grants to cover an estimate of \$150,000 for repairs in that area and to rebuild Well House 3. Backhoe operators we have used in the past are not as available for a variety of reasons. We are currently searching for replacement operators who may be more available. Finding skilled labor is getting harder and harder in the Brazos. We still have to maintain a conscious effort on conservation. We do not have an aquifer. We depend on snowfall and rain running through fractured rock in order to produce water from our wells. It is tough up here on dry years to produce water so let's never forget that. Thanks to everyone for their conservation and helping the association in getting through 2021. We are all in this together, which is why it's called a Mutual Water System. Our system relies on the run off to recharge the water supply. The link below is a good read on water availability outlook in New Mexico. <https://abq.news/2022/01/how-much-water-does-new-mexico-have/>

We **ALL** must conserve and save water every way we can. Remember, no outside watering or car washing. Be sure you have NO leaks at your cabin site—especially check for dripping faucets, running toilets, and leaking stop/waste valves (which has been pervasive). The board is taking a more proactive role in issuing fines for negligence and excessive water usage by checking meters annually and sooner if need be.

Web Site

The official association website (www.bmdwca.com) has been up and running since April of 2019 with new additional information. Our site is registered with the USPTO (United State Patent and Trademark Office). We have also utilized the PayPal function for those who wish to pay their water bill electronically. We post information about board meetings, and system operational service information to keep everyone up to date. Items posted are upcoming meetings, agendas, draft/final minutes, and the treasurer's report monthly. We also post urgent messages regarding water conservation, outages, and system maintenance when the need arises. Be sure to check the official website often. We are having 50-400 hits per month, so we know many are utilizing this website. We strongly encourage you to check the website prior to coming up each and every time to see if there are any water issues you will need to know about before starting your trip.

Association Background

The BMDWCA is a public water utility with a service area that encompasses approximately 120 acres in the Brazos Canyon. The utility's service area is roughly bounded to the east by Corkin's property, to the south by the Brazos River, to the west by Serenity Drive and to the north by Blue Jay Lane and Hilltop Road. The association has 128 user members, 16 non-user members and 1 commercial-user member. The BMDWCA maintains approximately 20,000 feet of water distribution lines and two (2) storage tanks with total storage capacity of approximately 86,000 gallons. The utility derives water from three (3) water wells, and soon to be from the new supplemental well.

The association is regulated by the New Mexico Environment Department-Drinking Water Bureau in matters of maintaining and demonstrating compliance with regulatory drinking water quality standards and system design, materials and maintenance. The association is regulated by the New Mexico Office

of the State Engineer (OSE) in matters related to maintaining adequate water rights to meet our demand. The association is also regulated by the New Mexico Public Utilities Regulation Commission in matters related to authorized service area and rights of way.

By law, we are required to have a budget that allows us to keep track of expenses and income to operate the water system. We are a small water system with limited resources. We obtain finances for operating and maintaining the system from annual fees shared among all association members. The annual fees are periodically reviewed and adjusted by the directors to ensure that adequate budget is available for recurring system and financial operating costs, plus reasonable contingency costs for system repairs. Since portions of our distribution system are dated and near or past their design service life, we also maintain a fund to underwrite costs for annual system upgrades and line replacements to ensure a well-maintained system.

Work of the association is performed by a handful of skilled and dedicated professional contractors, as well as by the generous donation of time by members of the BOD. The directors ask you to take ownership of your water utility and do your part to ensure we have a good system now and in the future. Consider serving a term on the BMDWCA Board. We need to relieve those who have served many full terms.

Board of Directors/Terms and Other Personnel

Current BOD members and their terms are summarized as follows:

<u>Name</u>	<u>Position</u>	<u>Term Expires</u>
John Hoffman,	President (deceased)	2020
Jim Walker,	Vice-President (acting President)	2020
Marco Lucero,	Director	2022
Jay Mason,	Treasurer	2020
Arch Wells,	Director	2021
David Oelschlegel,	Secretary	2021
Eddie Kilmer,	Director	2021
Richard Dramer,	Director	2022
Curtis Goodfellow,	Director	2022

The association maintains contractual relationships with professionals to operate and maintain the system and to perform financial tasks such as billing and accounting as follows:

<u>Name</u>	<u>Position</u>
Levi Sandoval	Maintenance Operator (under contract)
Gretchen Denman	Bookkeeper
Nick Loftis	Tax Accountant
Déej Banister	Custodian of Records (non-salaried)

Association Financial Summary

The association operates on a fiscal year that runs from April 1 until March 31 of the following year.

Assets

The association maintains financial accounts in the New Mexico Bank and Trust and in Fidelity Investments.

The BMDWCA has the following financial assets as of March 2022

New Mexico Bank and Trust	\$ 4,536.30	2021 8141.39
Fidelity Cash	\$ 5,614.81	13558.38
Fidelity Investments:		

Thompson Bond Fund	\$ 5,023.36	751.62
FT8FX	\$ 62,077.24	60,532.00
Total Checking and Investments	\$ 77,251.71	66,984.19

Current Liabilities

<u>Loans</u>	<u>Annual Payment</u>	<u>Loan Balance</u>
2000-04	\$ 0.00	\$ 0.00
2005-02	\$ 1,684.81	\$ 6,262.62
Note RIP00033	\$ 0.00	\$82,103.18 ← NEW THIS YEAR

Expenses

Average monthly expenses, including electrical power, insurance, contract labor and water treatment chemicals are approximately \$2500. Coupled with debt service costs, we anticipate that the association's monthly costs are approximately \$4,350. There are other expenses regarding water rights adjudication and audit fees. All of these fees and expenses are part of our budget.

Revenue/Projection Income

The expected income for 2022-2023 will be approximately \$58,550 from the following sources:

Non-User Fees	\$ 1,760.00
User Fees	\$ 55,040.00
Commercial Fee	\$ 750.00
Investment	\$ 1,000.00

Financial Audit

State law requires that an audit be performed every year to comply with the requirement set forth in New Mexico Environment Department-Drinking Water Bureau Regulations. The association retained the Hinkle & Landers Group to perform the audit for years 2018, 2019, and 2020. Hinkle is currently beginning work on the 2021-fiscal year.

Mailing Addresses/Phone Numbers/Property Changes

Members are obligated to keep contact information current. Please notify the association of any changes in mailing, phone numbers, and property transfers. Please remember that if you sell your property, you have 90 days to get a note to the board secretary releasing your membership and the buyer must go on the website to get the transfer form completed, along with a copy of the deed, and a \$50 check. If this transfer goes past 90 days, the old membership will be canceled and a new membership will need to be issued at \$6,000.00. Our bookkeeper keeps the email list, which can be updated on your annual bill correspondence. We will continue to utilize The official Brazos website with mass communications, and other pertinent information. Again, the address of the official website is (www.bmdwca.com)

Water Rights

Our attorney has put the final touches on the 40-year water plan that was submitted to the State OSE this February. The OSE wants us to have a current plan however they want us to reduce our agreement from 48 acre feet to 17.1 acre feet. The board approved the current plan and we are waiting upon the OSE. This should have no affect on us getting our final permits for Well 1A and the new supplemental well.

Fire Hydrant Testing/Water System Flush

Yearly, the Brazos Canyon Volunteer Fire Department and the association's maintenance operator team up to flush the water lines and test the fire hydrants. Flushing the water system may result in temporary discoloration of the water due to the mineral sediments collecting in the water lines over the year. We published on our official Brazos website these dates in 2021 to make members aware of the activity. The directors recommend that you store some drinking water so that you have some available if water becomes discolored after the testing. If you have any questions, do not hesitate to contact a Board member, and continue to check the Official Website (www.bmdwca.com) for specific information regarding this effort.

Water Conservation

Our water system has limited storage and well capacity. On weekends and holidays when most residents are in the Brazos, it is a struggle to keep up with demand. Even small leaks can rapidly deplete our system. The board earnestly asks every member and their guests to refrain from wasting water and to identify and fix residential leaks. Last year we had far too many stop and waste leaks, which cost the association and community a great deal of time, effort, and money. Please keep in mind, a stop/waste valve is designed to leak if it is not fully turned to the off or on position. If it is not fully open or closed, it will leak. Multiply that by many cabins and there is a huge loss of water. We strongly encourage a two (2) ball valve system when replacing a leaky stop and waste valve. A main ball valve to your cabin with a drain ball valve for winterizing. (See image on last page). It provides a positive on or off to avoid leakage. We did talk to a plumber in Santa Fe, who is more than willing to come out for your plumbing needs. We know finding plumbers is getting difficult, so here is the contact information should you need a plumber. Please let the board know if you have a plumber who is willing to come out to the Brazos. (Cartwright's Plumbing, Heating and Cooling- P.O. Box 16371, Santa Fe, NM 87592. Jose "Pepe" Torres, 505-982-2511 or cell 505-819-8451. Email: 8451tech@gmail.com. www.cartwrightsplumbing.com)

Shut-Off Valve Compliance

Each meter vault is equipped with a valve that is intended to disconnect your water service only in the event of an emergency, or non-payment. It is your responsibility to maintain water line infrastructure for plumbing on the user's side of your designated water meter. In 2012, the board issued a requirement that all users must have a functioning user-owned shut-off valve for service by 8/20/2014, Rules and Regulations, VIII.5. Problems with leaks in our system are an ongoing concern. This year the Board is recommending a two (2) ball valve system, should you need to replace your leaking stop and waste valve. If we find a leaking stop and waste valve, we will shut off the meter, notify the user, and the repair is up to the owner to complete. The water meter valve cannot be the only shut-off valve on a water line. As a reminder, using the meter can to turn your water off and on is a federal offense.

New Well

In 2020, we contracted with an Albuquerque Engineering firm and got the new supplemental well drilled. We paid for that drilling out of General Funds. It is around 250' deep and was producing an average of 5GPM. The well is next to the Upper Tank. The board has secured a low interest loan from the State which has been approved. We have been issued an Emergency Use Authorization Permit (temporary) where we can start pumping as soon as the project is complete. Our next step is to get the final well permit (April 2022) which is in progress, and work with Sierra Engineering to get the power, chlorination, plumbing and well house from the well to the tank completed. Once operational, this well should help us, especially on high demand weekends. We have had many setbacks on the new well progress primarily due to the all the issues surrounding the bogus Well 1A locations established back in

2009, and Well 1A never getting permitted since 2009. The State OSE was holding back our entire permitting operation to complete the well until all these erroneous sites were addressed. After 16 months of meetings, emails, and phone calls with the State OSE, our attorney helped us get through many of the roadblocks that were created in the past. We have now cleared all the bogus Well 1A sites with an Affidavit, have an Emergency Use Authorization Permit for both Wells 1A and the new supplemental well, which allowed us to finally move forward. We still have to deal with the old Well #3 plugging plan, but that issue is not as pressing. The next major task was getting easement permission from three landowners to bring power from Falls Creek Road to the new supplemental well. After several failed attempts, we found a new path and got the easements agreed to and recorded. We had a bid to cut trees as high as \$10,000, so three of the board members committed to a 3-day weekend and cut down over 100+ trees for the easement. Thanks to David Oelschlegel, Richard Dramer, and Jay Mason for the very hard work. They went through several chain saws at their own expense. This is the kind of dedication that you have on the board today. A very special thank you to Clay Kilmer. Clay has been instrumental in helping us move the well projects along. We have awarded a bid to File Construction in the amount of \$146,000, for Phase II infrastructure. We hope to have this project completed by the summer of 2022, if not sooner. File Construction is about 50-60% complete on the new well infrastructure. We had two (2) active loans, and one was paid off in July 2021. The second loan will mature in 2025. The preliminary work has been done for the loan on the Supplemental Well to be set up in the summer of 2022.

Rate Changes

During all the negotiations with our loan with the State, we learned that the Brazos is significantly below the rest of New Mexico associations on rates. Our last rate change was in 2004 at \$430 plus tax per year. 18 years without an increase! The Rural Water Association, New Mexico Environment Department and the State of New Mexico Drinking Water Bureau have confirmed that our current rates are extremely below average rates when compared to similar co-ops. The BMDWCA Board that was in place in 2009 noted that they were aware of this significant rate difference. Our expenses were higher this past year, where we needed to tap into some investment accounts to pay bills. According to the U.S. Bureau of Labor Statistics, inflation has increased 2.63% per year since 2004. However, April of 2022, inflation rates rose to 8.5% and are moving in the wrong direction. From January 2021 to April 2022, an increase of 1.4% to 8.5% represents an inflationary increase of over 500% in just 15 months. Rural Water Association and the State have confirmed that we are about 15-20% below the state average on our water rates. Running below par will affect our ability to secure loans and grants since the State of New Mexico looks at our income to expense ratio to justify funding. Our system is dated and is in constant need of upgrading and repair, therefore, having the funds to address this constant need will be absolutely necessary.

Adjusted for inflation our rate should be \$627/yr. However, the board felt that rate would be too high. The board passed a 15% increase at the 11/14/21 meeting. The board passed changing the Rules and Regulations to match on 12/19/21. Unknown to the board, we discovered through our attorney that all increases 2% or higher must go through the Public Regulatory Commission (PRC) with a great deal of administrative activity. Therefore, at the 2/27/22 meeting we had to strike down the previous motions for the increase, and Rules and Regulations changes to revert back to the original amount. Shortly after this activity, a call to the PRC indicated we do not have to go through the PRC unless there is a board decision to place us under the PRC. Therefore, the board will need to address this in the next billing cycle for the Brazos.

If you have any questions regarding your water service, do not hesitate to contact a board member.

Thank you,

Jim Walker
Vice-President
Brazos Mutual Domestic Water Consumers' Association, Inc.

Cabin Ball Valve Main and Drain Image

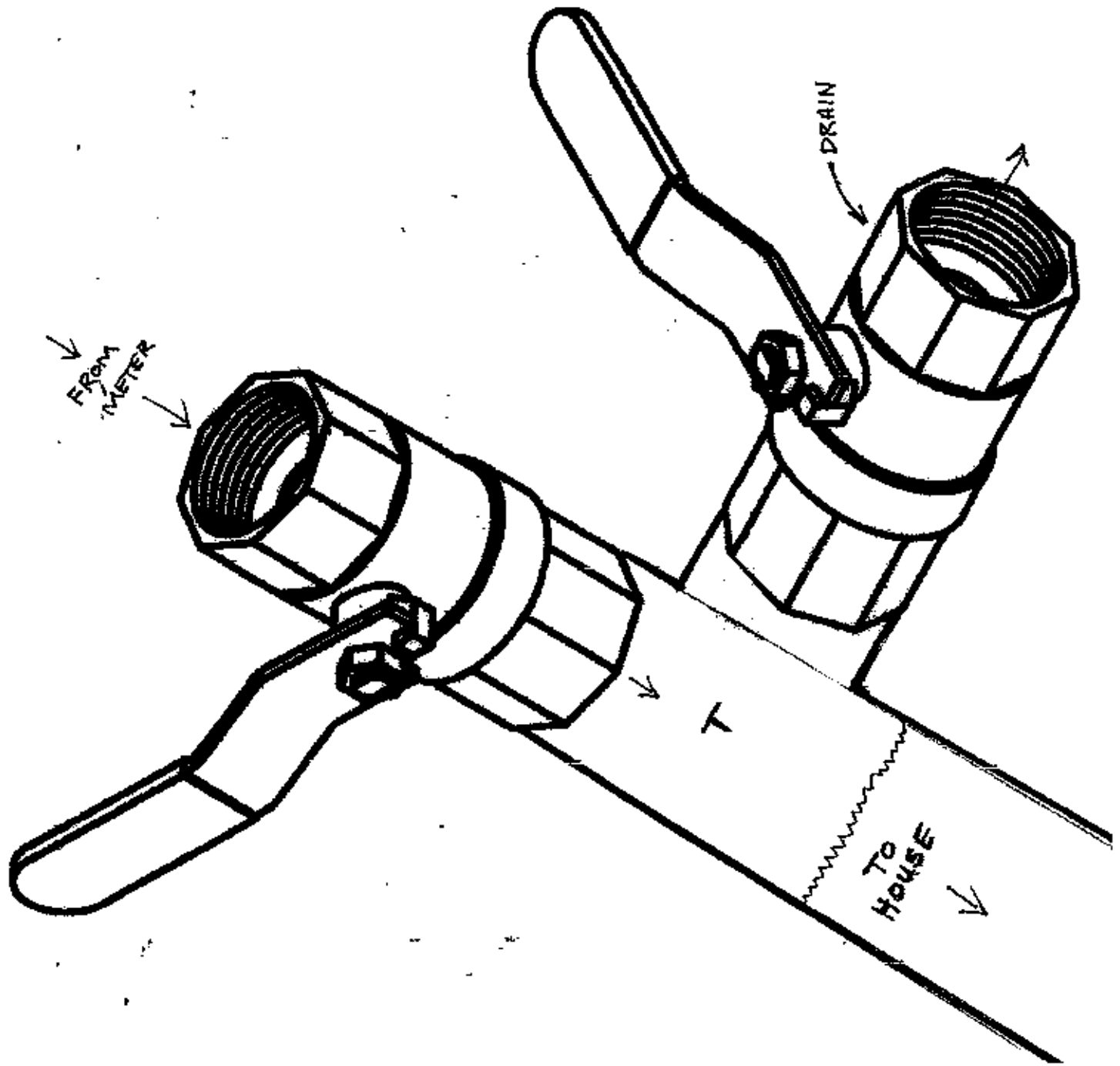

10/10/10 10/10/10 10/10/10 10/10/10 10/10/10

10/10/10 10/10/10 10/10/10 10/10/10 10/10/10



Brazos Members: As of the time of this mailing, we still have not found our demon leak, therefore we still have no storage. We are desperately trying to get a Grant to rebuilt well house 3, which requires an engineering stamp per the State. We have requested \$150K for the project. We also plan on getting a contractor back up to pot hole well house 3 in an attempt to locate the problem area. NORA cannot install our power line until late May for the new well so we are wanting folks to know if you come up, you will need to **bring water until further notice**. We were able to keep the lines full throughout the winter despite the many power outages, however as people start coming up this Spring, that will not be the case. So come prepared. We are doing all we can to solve this leak, and get the new well on-line. Then we should be in good shape. Also, you may have seen where NORA is doing a major upgrade on April 29th, 2022 with a 10 hour outage. Please be prepared. **Please check the Website:** We will keep the Website updated weekly on progress and current status. (www.brazoswater.com).

Thank you

**BRAZOS MUTUAL DOMESTIC WATER CONSUMERS ASSOCIATION, INC.
NOTICE OF ANNUAL MEETING**

In accordance with the Bylaws, the annual meeting of the Brazos Mutual Domestic Water Consumers' Association, Inc. will be held at 10:00am at the Brazos Fire Station on Saturday May 28, 2022..

The order of business will be:

- A. Call to Order
 - B. Proof of Quorum
 - C. Proof of Notice of Meeting
 - D. Reading of Minutes
 - E. Reports of Officers/Directors
 - F. Old Business
 - G. New Business-Bylaw Change
 - H. Election of Directors
 - I. Adjournment
-

2022 BIOGRAPHIES FOR BOARD OF DIRECTORS CANDIDATES

Jim Banister

Jim and his wife Martha reside in Chandler, Arizona. Jim was born in Los Alamos. After attending Arizona State University, Jim was employed by a residential home developer in the Phoenix area, Homes by Dave Brown, as a building construction superintendent. After 12 years with Brown, Jim obtained his contractor's license and started his own building and maintenance company which he successfully maintained for 25 years until his retirement. His expertise in the construction and maintenance business would be most beneficial to the water board. Jim has been coming to the Brazos for over 40 years. His parents are full-time residents in the Upper Brazos Estates and have owned a cabin in the area since early 1980's. In 2016, Jim and Martha started construction of a cabin on Aspen Drive and became fulltime seasonal residents.

Amanda Urioste

I am a lifelong resident of Albuquerque; my husband and I met at Valley High School in 2000 and share 2 wonderful kids and 1 granddaughter. We just recently purchased our piece of heaven in the Brazos. it's a place our family has spent the last year working hard and enjoying every minute of our adventure. I currently work as a Quality Assurance Software Architect for PNM resources. I have spent 15 plus years working in various IT & Regulatory compliance roles for Local and State Government Agencies, and now in the Electrical Utility industry. I am excited and appreciate the opportunity to volunteer for the water board and look forward to any contribution I can make to the Brazos Community.

Chris Denison

My name is Chris Dennison, and I am interested in becoming a member of the Brazos Mutual Domestic Water Consumers Association board. I am a full-time resident of the Upper Brazos, and feel that by being such, I will be able to provide real time assessments and updates for the community.

My goal as a member will be to encourage transparency, communication and participation. I believe that these three items are crucial for us to move forward as a community. Every homeowner in our scope of service will be fully informed of what the board is working on and spending money on, have this information communicated directly to them, and be encouraged to participate in the decision-making process.

I will draw upon my multiple years of experience as a member of the Homeowner's Association where I lived in Colorado, prior to make the Upper Brazos my permanent home. I was a member of the Architectural Committee and was responsible for reviewing and approving homeowner projects in a timely fashion. I also am a licensed Realtor in both Colorado and New Mexico. I have held my Colorado license for 17 plus years and a quickly

becoming familiar with the New Mexico market as well. I feel that my experience and availability resources in the area will also prove to be useful.

Irv Lindemuth

My wife, Hedy, and I have owned our cabin in the Brazos for 28 years. We have spent the last 19 summers as full-time residents. I have previously served the Board for more than eight years, including as vice-president and webmaster. I want to return to the Board to re-establish the transparency, open communications, fiscal accountability, and system reliability that existed when I stepped down from the Board in 2014. I believe members care more about the Association than just whether or not there is water in their faucets. Since leaving the Board, I have maintained a website (brazos-water.com) to provide Association members with information that was simply not available otherwise, and I will ensure that members are kept up to date regarding the water system operational status and the financial business of the Association. As a full-time resident of the Brazos during the crucial summer months, my previous experience on the Board and my in-depth knowledge of the water system will enable me to monitor the system in real time and take immediate steps to rectify leaks, water shortages, and other operational problems. In addition, I will be able to provide immediate assistance to members who have water problems or questions about the water system.

Bob Cooke

My family bought the property on Blue Jay Lane in the Brazos in 1963 when I was 3 years old and built a house over several years. I moved from Albuquerque into that house full-time in 1998, so I have been a local resident for 23 years. In the early 2000's, I was one of the founding members of the Brazos Canyon Volunteer Fire Department. Currently I am a teacher at Escalante Middle/High School.

Through the years I have seen and heard of many issues concerning our water association and feel its time for me to run for Board Membership. As a full-time resident, I have a daily concern whether we have high-quality water without worry. I once met a man from Kuwait (a wealthy country in the Middle East) and asked him, "What is the biggest difference between living in Kuwait versus the United States?" He answered, "In the United States, you have water when you open the faucet." I would like to make sure The Upper Brazos always has water.

Having served on the Dulce Schools Board of Education for a 4-year term, I am familiar with working closely with other board members and regulatory entities. I believe in the following:

- Transparency—nothing should be hidden from any members or customers of the Brazos Mutual Domestic Water Consumers Association, Inc.—less suspicions of impropriety grow.
- Communication should be regular, open, and truthful with meeting minutes posted.
- Data should be our driving force in an apolitical fashion.
- Board meetings should be held in The Upper Brazos, and those meetings need to be open to the public.

By the way, I had an auto shop for over 14 years in Albuquerque, and I am very familiar with mechanical, electrical, and hydraulic systems and repairs. I am a jack of all trades and think logically to troubleshoot problems.

I will serve to the best of my ability. I appreciate your vote.

William Silva

I am originally from Santa Fe moved to Albuquerque shortly after my military service. I purchased my cabin located next to Cliff View restaurant eleven years ago from Danny Butler and spend time here as often as I can throughout the year. I retired as a counselor for the Albuquerque Public Schools after forty years and I was also in charge of the Albuquerque Metropolitan DWI and Driver Improvement School for thirty years.

My main qualities are that of being an excellent communicator, listener and getting the job done by working hard. Unfortunately, during my time spent here I have heard of many concerns and issues that have not been addressed properly to the community. Some of the concerns and issues are lack of communication, lack of transparency, financial concerns, Board meetings held in Albuquerque rather than The Upper Brazos and most important are the water issues of the highest priority.

If elected to serve on the Board I would do my best to implement the following:

- Communicate to members by sending out current information via e-mails and addressing all concerns and issues in a timely manner
- Hold open meetings here at The Upper Brazos
- Transparency by having members not be afraid to call board members

I have a lot to learn but will commit to learn by asking questions, attending meetings and getting involved knowing that I am here to serve the members. I would appreciate your vote for the upcoming Board elections.

Karen Adams

Our cabin is on the corner of Deer Lane, and Fall View Rd. We have owned our cabin in the Brazos for 11 years now. We are semi full time up here, meaning that we live in our cabin approximately 6 months out of the year.

I have served on the water board years ago, for only 6 months, to help finish out a term for someone that left the board. Honestly, I was fairly new to the area and didn't know what I was doing. Coming from the city, I just thought you turned on the faucet and there was water! If you paid you bill of course.

I have learned a lot since then, and now have a real good idea, of what is necessary to get the water flowing and how to do it. I am not afraid of hard work, and am more than willing to do what it takes. I don't pretend to know all the answers but I am really good at learning where to find them.

I would appreciate your vote, in the 2022 Water Board election.